



TECHNICAL DATA
FROM
Anemostat[®]
INTERNATIONAL
A MESTEK COMPANY

Kildare House • Wildmere Road
Banbury • Oxfordshire • OX16 3JU • UK
Tel: + 44 1279 812958 • Fax: + 44 1279 817771
e-mail: sales.eu@anemostat.com

Lo-FP
ROUND

LO-PROFILE METAL VISION PANEL
FIRE RATINGS

EN-1634
European Standard

B.S.-476.22
British Standard



UNDERWRITERS'
LABORATORIES



WARNOCK
HERSEY

DETAIL DRAWING

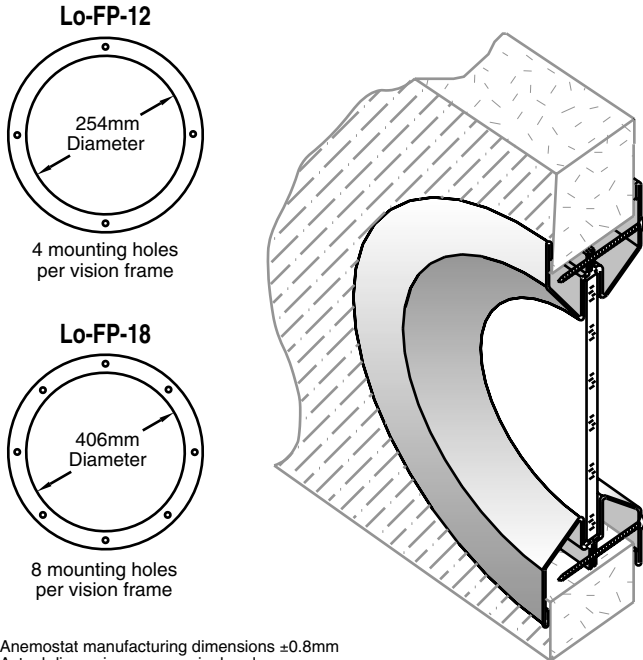

Anemostat manufacturing dimensions ±0.8mm
Actual dimensions are nominal and may vary
based on component manufacturers tolerances.

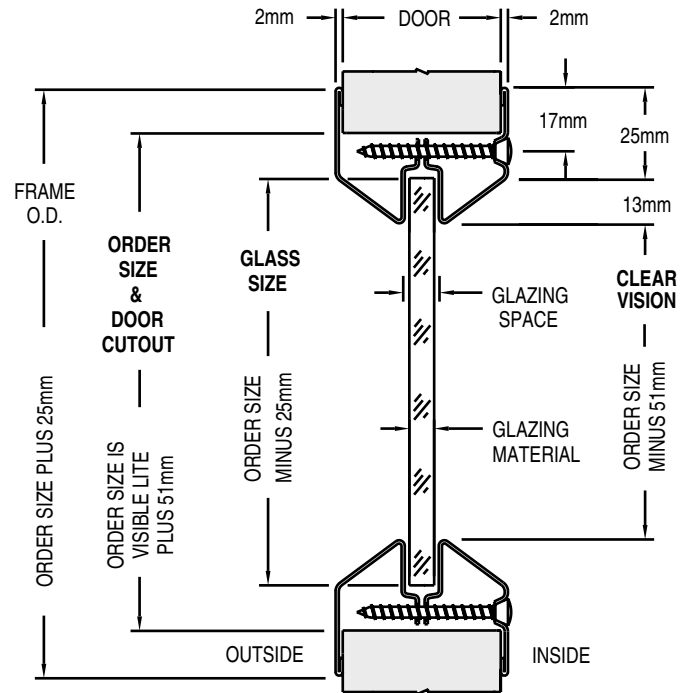

STANDARD PRODUCT FEATURES

- **MATERIAL:** 1mm Galvanised Steel
- **FINISH:** RAL 9006 Silver Baked Enamel
Lo-FP-12 stocked in #304 stainless steel
- **INSTALLATION:** Uses 44mm sheet metal screws that pass through the door cutout, and fastens to the opposite side of the vision frame, thus eliminating the need to drill holes into door saving installation time and labor. It also leaves the corridor side of the frame free of fasteners for added security and a cleaner, more aesthetic appearance.
- **DOOR THICKNESS:** For 45mm to 70mm Wood or Metal Doors.
- **GLAZING:** 5mm to 27mm Fire and/or Safety Rated glass.
Must specify glass and door thickness.
- **AESTHETICS:** Smooth round contour of low profile frame style gives a unique design to any setting.
- **IMPORTANT:** Interpretation of building and fire codes may vary. Consult with the local authority having jurisdiction in your area, to determine appropriate standards.

OPTIONAL FEATURES (SPECIAL ORDER FROM FACTORY)

- **MATERIAL:** #304 or #316 Stainless Steel, #4 Finish (Satin), Galvanised (Hot Dipped, or Electro Plated),
- **FINISH:** Custom Baked Enamel Colors (as per sample chip supplied). Plated Finishes to match the lock, hinges and closer.
- **FASTENERS:** Special Security Screw Fasteners,
- **SPECIALS:** Consult Factory for special diameter sizes

FIRE RATINGS (BS 476.22 & EN-1634)

- **BS 476.22:** Timber Doors - 30 min. and 1 hour. Tested to 254mm x 762mm
Steel Doors - 2 hours (4 hours actual). Tested to 813mm x 813mm
- **EN-1634:** 30/60 min. integrity and insulation - Indicative Testing

FIRE RATINGS (w/ U.L. & W.H.I. classification markings)

- **20/45/60/90 MINUTE:** Approved listing at 79 sq.in. (0.051 sq. meters) visible lite.

| | |
|---------------------|--------------|
| Job Name & Location | Submitted by |
| | |

For Most Current Info, Consult Factory or check our website, www.anemostat.com